

CD-700(H2S) Transmitter Datasheet

(H2S Hydrogen Sulfide, RS-485Modbus)

General

The CD-700(H2S) transmitter can measure H2S (Hydrogen sulfide) concentration, temperature, and humidity. H2S ventilation and temperature control can be controlled through up to two relays.

For customer convenience, various outputs such as RS-485Modbus communication and analog voltage/current are optional supported.

This product is a world-class, highly reliable product made by ELT SENSOR technology, a company specializing in gas sensors with 20 years of experience.

This CD-700 series has a variety of products equipped with not only a H2S sensor but also more than 10 types of environmental gas and dust sensors. (CxHy, CO2, H2S, NH3, NO2, NO, SO2, H2S, O3, PM, etc.)

It is very convenient to use because it can measure, manage, and control complex gases by connecting various types of sensors in the same CD-700 format.



CD-700(H2S)
Without LCD-Display



CD-700(H2S)
(with LCD Option)

Application fields

Low concentration hydrogen sulfide sensor (0~100.0ppm) : Measuring hydrogen sulfide concentration in locations with transformers and hydrogen generation, etc.

Features

- **Sensor Technologies**
H2S (Electro Chemical, EC)
Temperature (RTC) and Humidity sensor (Semiconductor type) – optional order
- **Pre-Calibrated (Concentration, Temperature)**
Precise gas concentration & temperature calibration,
Individual inspection of all products before shipment
- **RS-485Modbus Communication (default)**
- **Analog (Voltage/Current) Output (4~20mA/0~10V) - Choice option**
Should be select only one output option between RS485modbus or Analog output.
- **Re-calibration function**
Zero only or Zero + Span user calibrations are supported
- **Change of relay value(only LCD option) : H2S, Temp. relay range is settable with button on Front Cover.**
- **Power** : 24V DC, AC.
- **Size**: 123mmx70mmx48mm (130g)

Ordering Information

- **CD-700(Gas) + Choice OPTION**

OPTION	ORDER CODE	OPTION SPECIFICATIONS
LCD DISPLAY	L	LCD Display
PCB COATING	G	PCB Coating
TEMP & HUMIDITY	TH	Temperature, Humidity sensor
ANALOG OUTPUT	A	Analog Output(Voltage/Current)
RELAYS	R	Relays
BUZZER	B	Buzzer

※ Example : H2S, LCD Display & Buzzer -> **CD-700(H2S)+L+B**

※ Notice : If you are a first-time purchaser, please send an email to our sales team to confirm the required specifications and we will contact you to confirm. (sales@eltsensor.co.kr)

Detailed Technical Specifications

OPERATING ENVIRONMENT

TEMPERATURE RANGE	-10°C ~ 50°C
HUMIDITY RANGE	0% ~ 95% RH (non-condensing), PCB Coating 'G' option : 0 ~ 99% RH
PRESSURE RANGE	1 ± 0.1 atm
STORAGE TEMP	0°C ~ 20°C (Storage at low temperatures below 0°C and high temperatures above 40°C may shorten lifespan)
EXPECTED LIFE CYCLE	2 years. (in air, Sensor module lifetime)

SENSOR PERFORMANCE

PRINCIPLE	H2S sensor : Electro Chemical, EC Temperature sensor: RTC(Optional) Humidity sensor : Semiconductor type(Optional)
SENSING RANGE	H2S 0.0~100.0ppm Temperature Measurement : -30°C ~ 70°C Humidity Measurement : 0 ~ 99% R.H.
ACCURACY	H2S : < ± 3 % F.S. Temperature : ± 0.5 °C (0°C ~ 40°C), ± 1.0 °C Other ranges Humidity : ± 3 % RH (20 ~ 80% RH), ± 5 % Other ranges
RESPONSE TIME	T90 : < 30sec, T60 : < 9sec
RESOLUTION	1 % F. S.
DETECTION LIMIT	2 % F. S.
ZERO REPEATABILITY	<3 % F. S. / year
SPAN REPEATABILITY	<5 % F. S. / year
WARMING-UP TIME	10 seconds (based on output), 2 minutes (based on accuracy)
OUTPUT CYCLES	1 second

ELECTRICAL DATA (INPUTS AND OUTPUTS)

WORKING VOLTAGE	24VAC ± 20%, 50/60Hz(4-wired) Or 24VDC ± 20% (3-wired available)
RELAY CONTACT RATINGS	1A 120VAC / 1A 24VDC
RS485 MODBUS	2 wired Half-Duplex typed Modicon Mod-Bus RTU mode 9,600 BPS is default. (38,400 BPS is option)
ANALOG OUTPUT	4-20mA (default), 0~20mA or 0/2~10V
(ORDERING OPTIONS)	Only one of RS485 or 4~20mA output can be used

Dimensions (unit : mm)

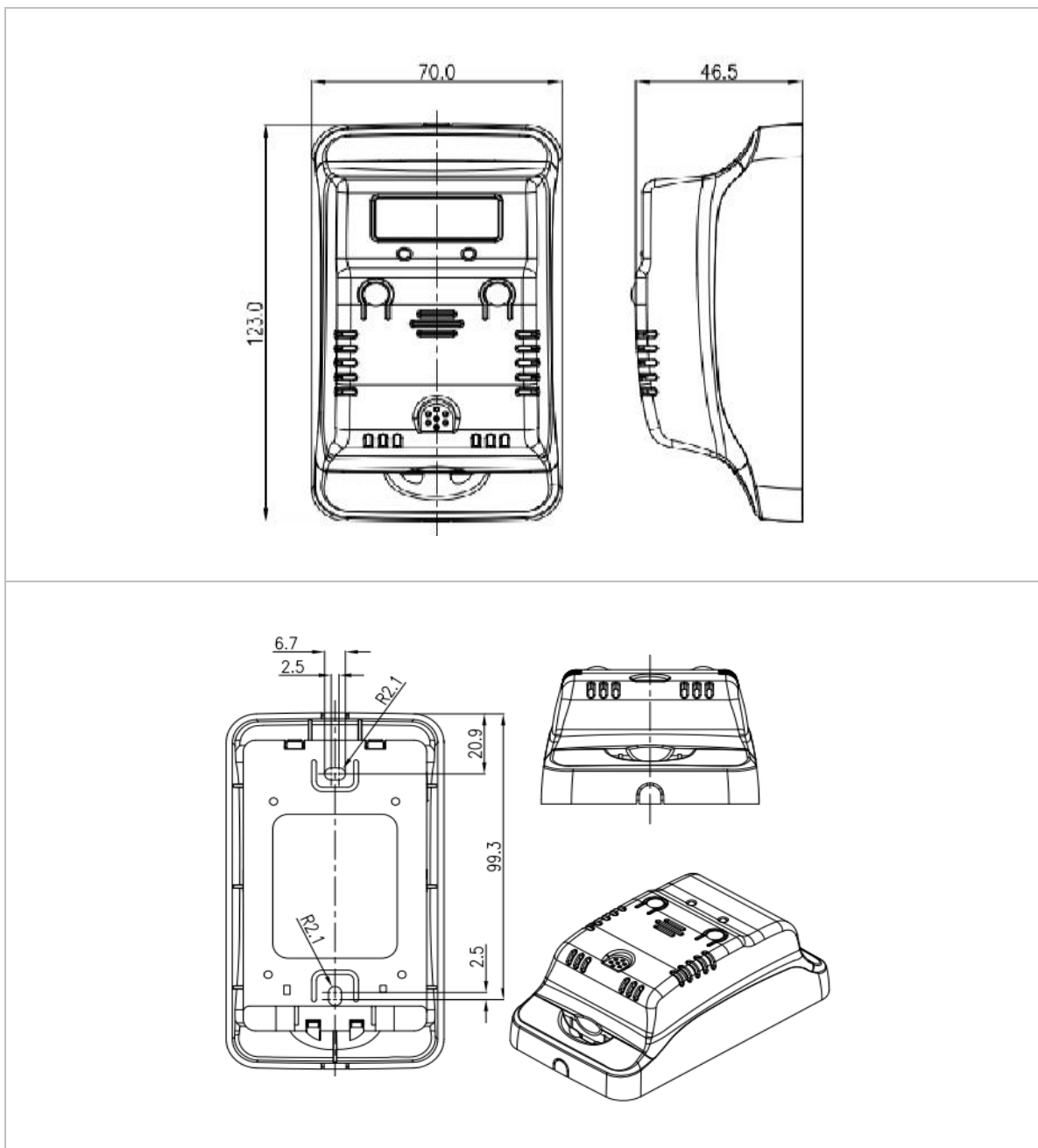

product packaging

Packaged in 1 paper box including all contents.

Contents : Main body, fixing screws(2pcs, 4x25mm), user operation manual

Wiring Method for 24VDC, 24VAC with RS-485modbus

For wired method, 24VDC/AC+ should be wired into pin-1 24VDC/AC- into pin-2, RS-485 -(B) into pin-3 and RS485 +(A) into pin-4 each (J1)

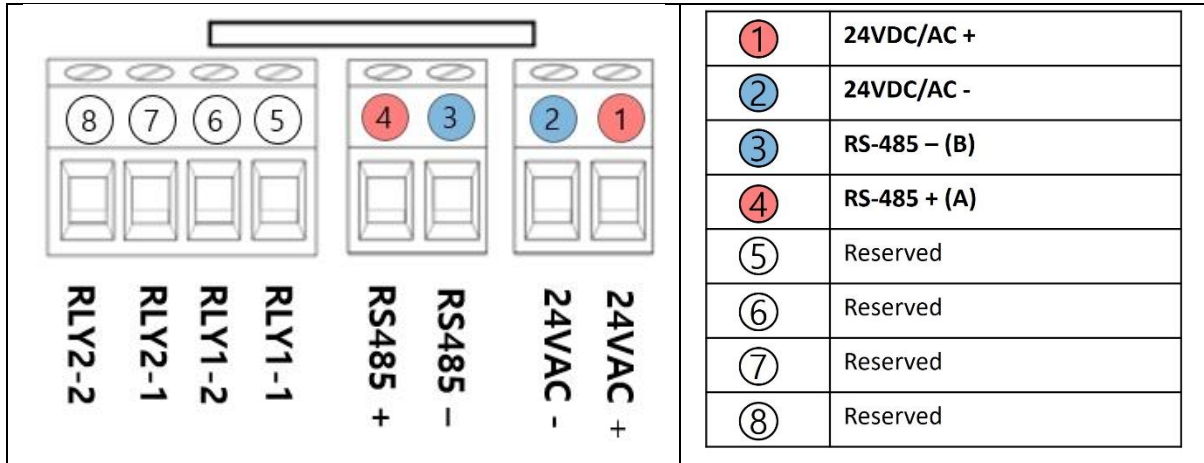

LCD Display (for LCD model, with Temp. Humidity options)

When equipped with a H2S sensor + temperature and humidity sensor, CD-700 with LCD option displays H2S (6 seconds), temperature (2 seconds), and humidity (2 seconds) alternately.

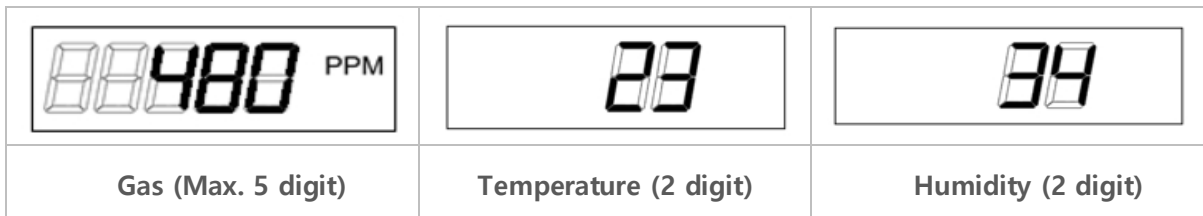

Two relay setting – H2S Gas, Temperature (for relay option)

Contract Rating : 1A/120VAC

Relay type: SPST (Single Point Single Throw), Relay Status H2S : N.O., Temp./Humid. : N.C. is default.

Buzzer-alarm : sounds for 30 seconds whenever the relay status is changed unless stopped by pressing 'B' button.

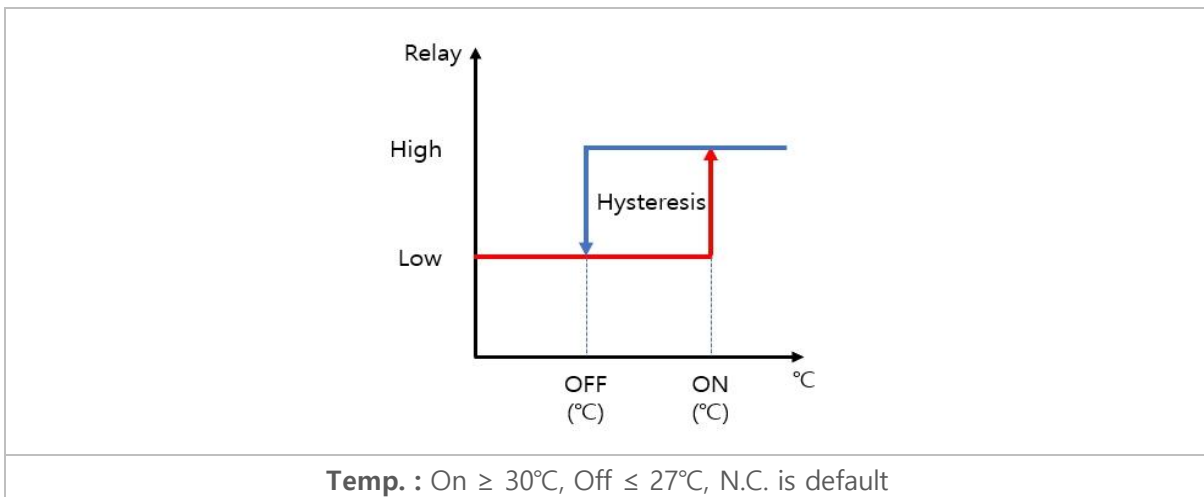
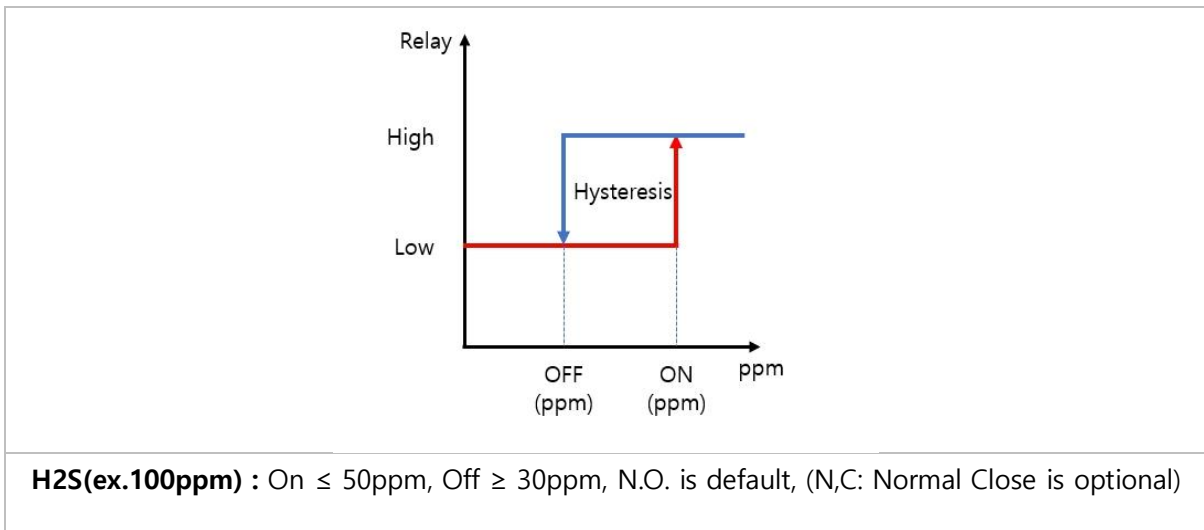
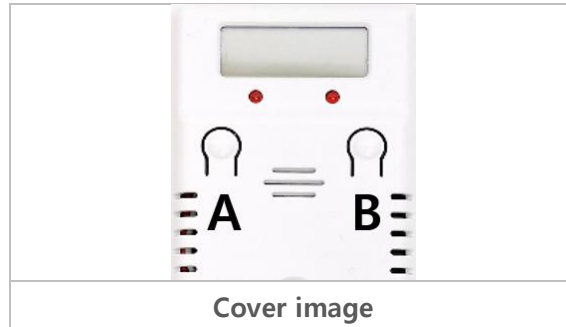

Alarm & Relays set value change. (for Buzzer option)

Buzzer-alarm get muted with short two beeps when 'B' button pressed for 2 seconds, unmuted with a short beep when 'A' button is pressed for 2 seconds.

High/Low alarm levels of three kinds sensors, Gas-sensor, Temp., Humid. could be changed by pressing button 'A' and 'B' through the flow chart below

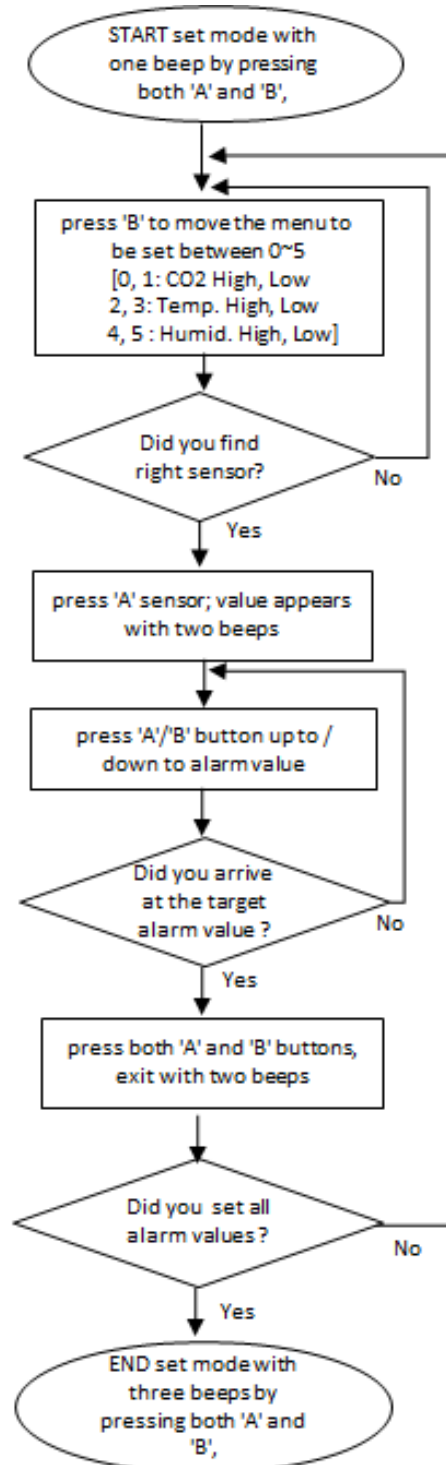

RS-485ModBus with Address

To measure and send signal using RS485Modbus, 2 wired Half-Duplex typed Modicon Mod-Bus RTU mode is supported.

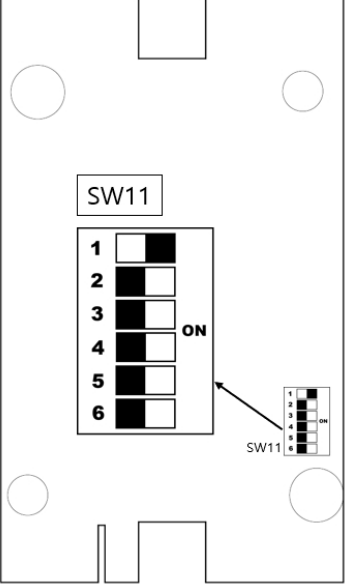
 <p>DIP Switch (LSB: 1, MSB:6)</p>	<table border="1" style="width: 100%; border-collapse: collapse;"> <thead> <tr> <th style="width: 30%;">Parameters</th> <th>Descriptions</th> </tr> </thead> <tbody> <tr> <td>Baud rate</td> <td>9,600 BPS is default. (38,400 BPS is option)</td> </tr> <tr> <td>Data bit</td> <td>8 Bits</td> </tr> <tr> <td>Parity bit</td> <td>None</td> </tr> <tr> <td>Stop bit</td> <td>1</td> </tr> </tbody> </table> <p>Parameter setting</p>	Parameters	Descriptions	Baud rate	9,600 BPS is default. (38,400 BPS is option)	Data bit	8 Bits	Parity bit	None	Stop bit	1
Parameters	Descriptions										
Baud rate	9,600 BPS is default. (38,400 BPS is option)										
Data bit	8 Bits										
Parity bit	None										
Stop bit	1										

- Hold Register Specification.
 - Mapping Base Address: 0x0050
 - Hold Register. Max. Read Size: 3
 - Supported Function Code: 3(Read Holding Registers)

Addr.	Value	Type	Unit	Output
0x0050	Gas	Word	ppm	558 (55.8ppm)
0x0051	reserved	Int 2Byte	°C	reserved
0x0052	reserved	Word	%	reserved
0x0053	reserved	Int 2Byte		reserved
0x0054	reserved	Int 2Byte		reserved
0x0055	Error.	Word	%	Error message

- Error code definition

Code	Descriptions
0x00	No error
0x01	Gas error
0x02	reserved
0x04	reserved

- Termination Resistor and Bias Resistor should be used as needed.

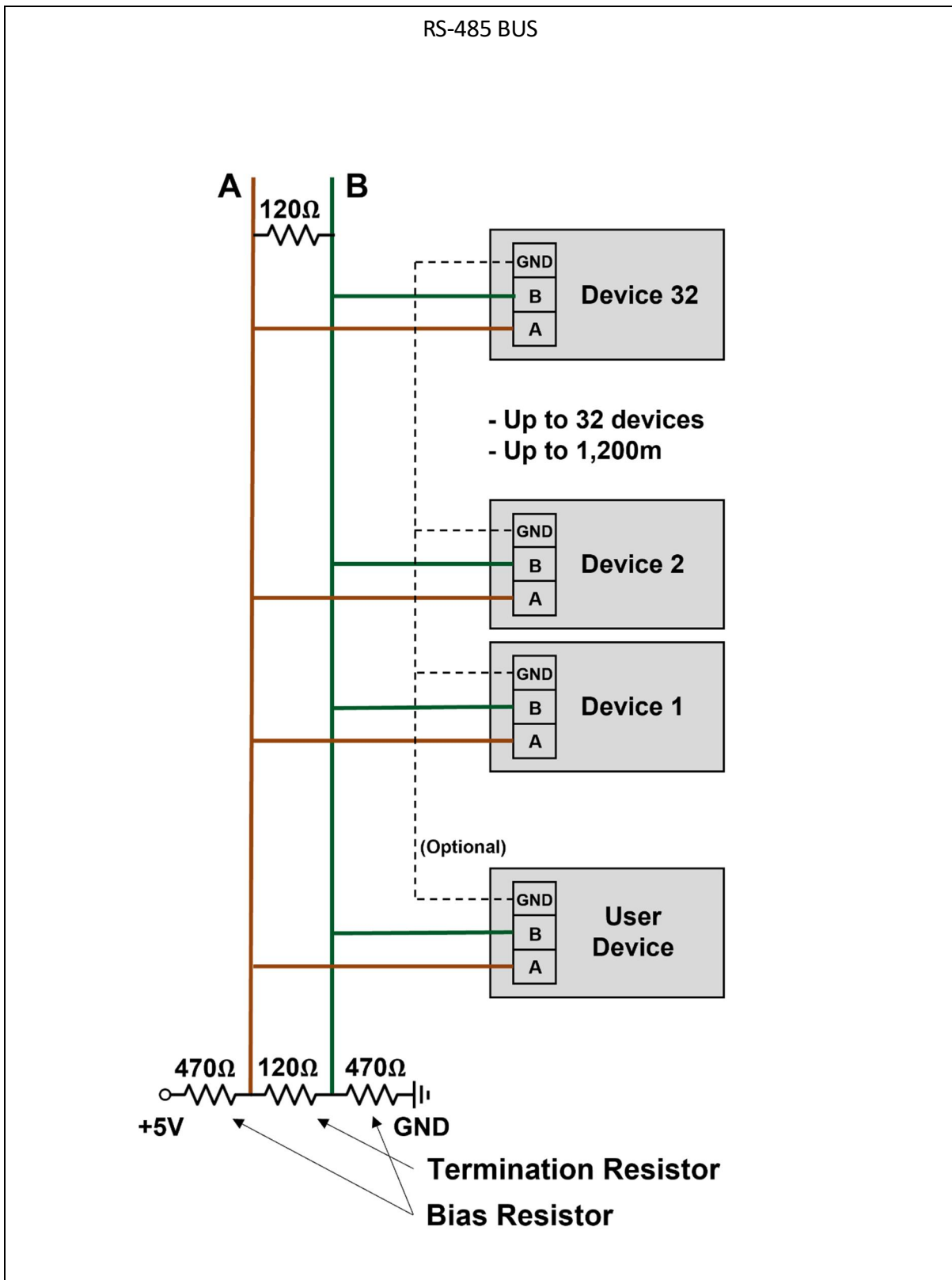

Output choice

Analog out output and RS485modbus output cannot be used simultaneously because they use the same output terminal.

[J1] Wiring Method for 24VDC, 24VAC, Analog Output (for analog output option)

24VDC/AC + should be wired into pin-1, 24VDC/AC - & Aout - & GND into pin-2, Aout + for Gas pin-3 and Aout + for Temp(option) into pin-4 each (J1)

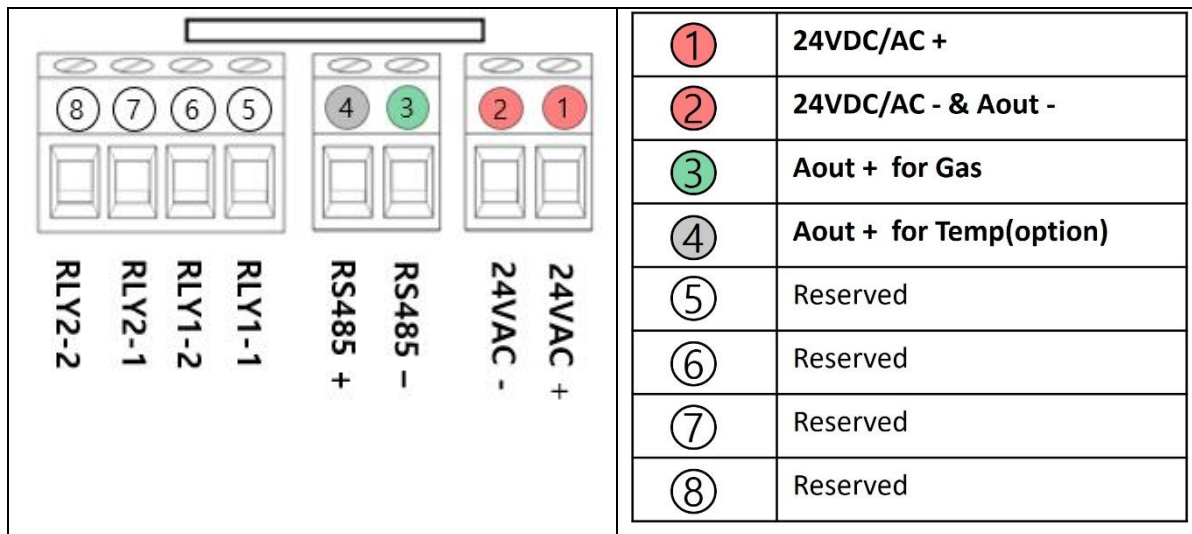

Analog output selection

■ SW32(H2S), SW31(Temp) : 4 ~ 20mA, 2 ~ 10V, 0~20mA, 0~10V. setting

Note : RS485Modbus communication is default and analog current of 4/0~20mA or analog voltage 2/0~10V or 1/0~5V could be chosen as option on issuing order.

Cross Sensitivity for Other Gas

CD-700(H2S)

Gas type	Concentration(ppm)	Cross Sensitivity(ppm)
Carbon Monoxide	100	4.5
Sulfur Dioxide	20	4.0
Nitrogen Dioxide	10	-2.5
Nitric Oxide	50	0.0
Ammonia	50	0.0
Hydrogen	1,000	4.0
Ethylene	100	0.2
Chlorine	15	-3.0
Ethanol	200	0.1

User Calibration using switch on main PCB or jumper on Sensor module

Users can only perform zero calibration in the field using the switch on the Main PCB as follows. (using two methods)

Method 1 : using the switch on main body PCB

■ J15 : Calibration selection (on main pcb)

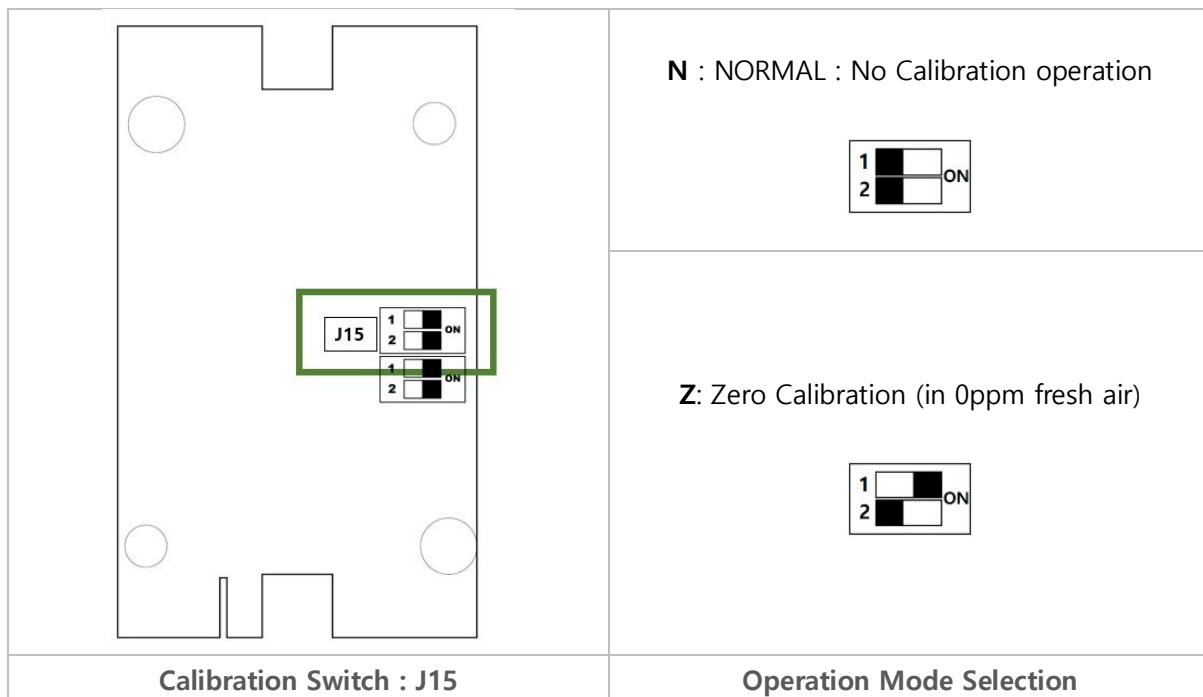

- **Z mode : Zero Calibration**

- Zero calibration method

- 1) Move the switch to this position for zero calibration.
- 2) Turn on the power and leave it in fresh air for more than 5 minutes.
- 3) The 0 ppm is automatically adjusted and stored repeatedly every 1 minute, and check that 0ppm is displayed, and turn off the power.

- caution

When performing only zero calibration, the switch must be placed in the normal position after zero calibration is completed.

If user want to perform zero-span calibration, user can separate the gas sensor module from the CD-700 main body PCB and calibrate it using a calibration kit.

Customers who wish to purchase a calibration kit contact the sales team

(sales@eltsensor.co.kr)

Method 2 : Using the jumpers of sensor module on main body PCB

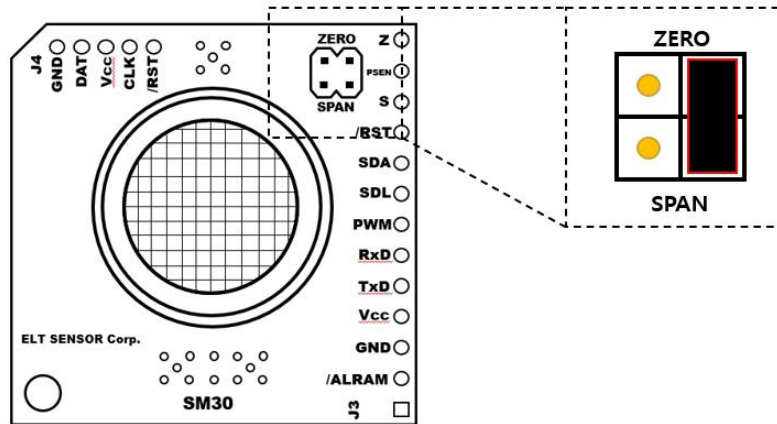

Using jumper on Sensor module of main body

● Jumper Position #1 (Using Normal)

Factory setting position	Field of application
<p>ZERO</p> <p>SPAN</p>	<p>H2S-gas-detector installed in H2S-gas-free area lest unexpected H2S-gas-leakage damages lives in residential buildings, commercial restaurants, lodging, or so</p>

● Jumper Position #2 (Zero Calibration)

setting position	Calibration process sequence
<p>ZERO</p> <p>SPAN</p>	<p>- Zero calibration method</p> <ol style="list-style-type: none"> 1) Please open the top cover of the product with the power turned on. 2) Move the jumper to this position for zero calibration. 3) The 0 ppm is automatically adjusted and stored repeatedly every 1 minute, and check that 0ppm is displayed. 4) After 5 minutes, return the jumper to its original position as indicated, and then reassemble the top cover.

Note: Only zero calibration is possible, but additional span calibration is recommended for high accuracy. (Span gas 50 ppm) of range ppm H2S, Air Based)

- Jumper Position #3 (**Span Calibration** – input the 50ppm H2S standard gas)

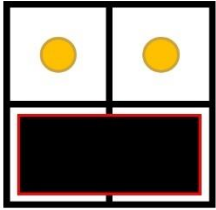
setting position	Calibration process sequence
<p style="text-align: center;">ZERO</p>  <p style="text-align: center;">SPAN</p>	<p>- Span calibration method - Prepare H2S standard gas(Refer to next table) in advance (Air Based).</p> <ol style="list-style-type: none"> 1) Please open the top cover of the product with the power turned on. 2) Move the jumper to this position for span calibration. 3) leave in a H2S span gas environment, and wait for more than 5 minutes. 4) Span ppm is automatically output and stored repeatedly every minute. Confirm that Span ppm (+- 5%) is displayed. 4) After 5 minutes, return the jumper to its original position as indicated, and then reassemble the top cover.

Sensor Name	Zero, Span Calibration Concentration	Manual Calibration Time	Recommended Cal. Period
CD-700(H2S) 0-100.0ppm	0 / 50 ppm	Every 1 min.	1 year

- cautions for user calibration

- 1) Be sure to perform span calibration after zero calibration.
- 2) When performing zero calibration, use atmospheric air or H2S zero Air is used, but nitrogen is not used.
- 3) When calibrating span, use air-based H2S standard gas. Since the electrochemical theory requires oxygen to react, if oxygen-free gas is injected for a long time, the sensor measurement value will be incorrect sensing.

CD-700 series gas types available to order

Various gas types and measurement ranges that can be ordered with the CD-700 series

Gas No.	Order Gas Model	(GAS/Range/ increments)	Default Model	Option
1	CD-700(CO2)	CO2 (NDIR) 0~10,000ppm/1ppm	No LCD, Only RS- 485 Modbus (no other optional)	L : LCD G : PCB Coating TH : Temperature & R.H. Sensor A : Analog out R : Relay B : Buzzer
2-1	CD-700(CH4)	CxHy (NDIR): (0~5,000ppm/1ppm, 0~100 %LEL/ 1%)		
2-2	CD-700(C2H4)			
2-3	CD-700(C3H8)			
2-4	CD-700(C4H10)			
2-5	CD-700(C5H12)			
3	CD700(C2H4)	C2H4 (E.C.) (0~10/0.01ppm, 0~100ppm/0.1 ppm, 0~1000ppm/1ppm)		
4	CD-700(CO)	CO (E.C.) (0~1000ppm/1ppm)		
5	CD-700(H2S)	H2S (E.C.) (0~ 100ppm/0.1ppm)		
6	CD-700(NH3)	NH3 (E.C.) (0~100ppm/0.1ppm)		
7	CD-700(O2)	O2 (E.C.) (0~ 25%/0.01%)		
8	CD-700(NO2)	NO2 (E.C.) (0~20ppm/0.1ppm)		
9	CD-700(NO)	NO (E.C.) 0~ 5ppm / 0.01ppm		
10	CD-700(SO2)	SO2 (E.C.) (0~20ppm/0.1ppm)		
11	CD-700(H2)	H2(E.C.) (0~ 2000ppm/1ppm)		
12	CD-700(O3)	O3 (E.C.) (0~ 10ppm / 0.01ppm)		
13	CD-700(PM)	PM(PM10, PM2.5, PM1.) 0~1,000 µg/ m ³ /1 µg/ m ³		

Notice and precautions

1. When handling or installing this product, avoid physical, thermal, electric shock and high concentrations of corrosive gases, and be careful not to allow water to enter the product.
2. In this case, it may cause malfunction or shorten lifespan. Power should be selected within tolerance and wired into right position because the product could get damaged when 24V power input is inserted into signal output position.
3. Please install or keep the product away from the places where electro-static or induced electro-magnetic field exists.
4. The product's components should not be departed or replaced, or manipulated unless requested or agreed by vendor.
5. The product warrants solely to the original purchaser of this product for a period of 12 months (one year) from the date of delivery.
6. For any other inquiries, please contact our sales team. (sales@eltsensor.co.kr).